

PORTAHERRAMIENTAS MORTAJADOR PHZ

Características

Porta cuchillas mortajadoras.

Aplicación

Herramienta diseñada para trabajar el ranurado.

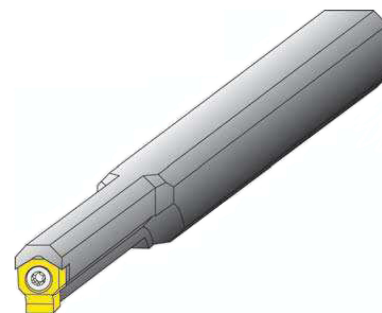
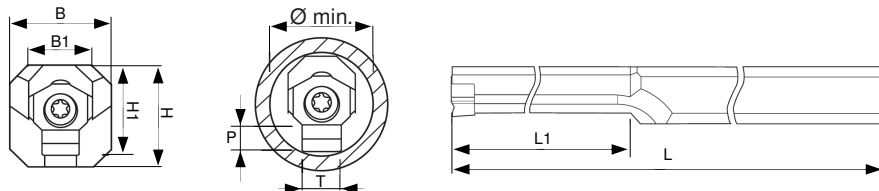

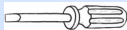
Referencia	H	H1	B	B1	L1	L	T	Ø min.	P máx.	Cód. Hta		
PHZ 90 1104-06	11.3	9	11.3	8.5	35	160	3	9.5	1.6	19147PHZ90110406	19147DVF3539	19147TX207PLUS
PHZ 90 1107-06	11.3	10	11.3	7	60	200	4 5	10.9 11.1	2.5 3.0	19147PHZ90110706	19147DVF3539	19147TX207PLUS
PHZ 90 1111-06	11.3	12	11.3	-	60	220	4 5	14.0 14.0	2.5 3.0	19147PHZ90111106	19147DVF3539	19147TX207PLUS
PHZ 1512-10	15.5	16.2	12	-	-	220	6 8	17.8 18.2	4.2 5.2	19147PHZ151210	19147DVF2260	19147TX215PLUS
PHZ 2014-13	20.6	21.5	14	-	-	250	10 12	24.2 24.7	6.2 7.2	19147PHZ201413	19147551302014	19147TX225PLUS

CUCHILLAS MORTAJADORAS HZ

Características

Cuchilla 333TN: esta echa de HSS + PVD

Aplicación

En el mortajado vertical que es en general de 90° a causa de los movimientos de la mesa paralelos o Perpendiculares al filo de la herramienta.

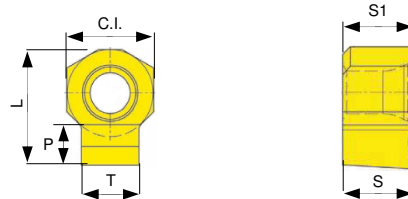

Referencia de la cuchilla	C.I.	S	S1	L	P	T	Tolerancias en T	Calidad	Cód. Hta
HZ 90 06 04-30 C11	6	4.66	4.76	7.5	1.6	3	+0.060 +0.012	333TN	19147HZ90060430C11
HZ 90 06 04-40 C11	6	4.66	4.76	8.0	2.5	4	+0.070 +0.145	333TN	19147HZ90060440C11
HZ 90 06 04-50 C11	6	4.66	4.76	8.0	3.0	5	+0.070 +0.145	333TN	19147HZ90060450C11
HZ 10 06-60 C11	10	6.25	6.35	13.5	4.2	6	+0.070 +0.145	333TN	19147HZ100660C11
HZ 10 06-80 C11	10	6.25	6.35	13.5	5.2	8	+0.080 +0.170	333TN	19147HZ100680C11
HZ 13 09-100 C11	13	9.40	9.52	18.5	6.2	10	+0.080 +0.170	333TN	19147HZ1309100C11
HZ 13 09-120 C11	13	9.40	8.52	18.5	7.2	12	+0.095 -0.205	333TN	19147HZ 1309120C11
HZ 90 06 04-30 H7	6	4.66	9.52	7.5	1.6	3	+0.090 -0	333TN	19147HZ 90060430 H7
HZ 90 06 04-40 H7	6	4.66	4.76	8.0	2.5	4	+0.012 -0	333TN	19147HZ90060440H7
HZ 90 06 04-50 H7	6	4.66	4.76	8.0	3.0	5	+0.012 -0	333TN	19147HZ90060450H7
HZ 10 06-60 H7	10	6.25	6.35	13.5	4.2	6	+0.012 -0	333TN	19147HZ100660H7
HZ 10 06-80 H7	10	6.25	6.35	13.5	5.2	8	+0.015 -0	333TN	19147HZ100680H7
HZ 13 09-100 H7	13	9.40	9.52	18.5	6.2	10	+0.015 -0	333TN	19147HZ1309100H7
HZ 13 09-120 H7	13	9.40	9.52	18.5	7.2	12	+0.018 -0	333TN	19147HZ1309120H7
HZ 90 06 04-30 D10	6	4.66	4.76	7.5	1.6	3	+0.060 +0.002	333TN	19147HZ90060430D10
HZ 90 06 04-40 D10	6	4.66	4.76	8.0	2.5	4	+0.078 +0.03	333TN	19147HZ90060440 D10
HZ 90 06 04-50 D10	6	4.66	4.76	8.0	3.0	5	+0.078 +0.030	333TN	19147HZ90060450D10

PORTAHERRAMIENTAS MORTAJADOR PHZ/2



Características

Porta cuchillas mortajadoras.

Aplicación

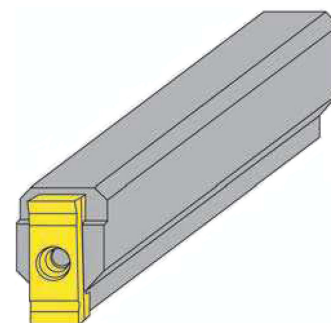
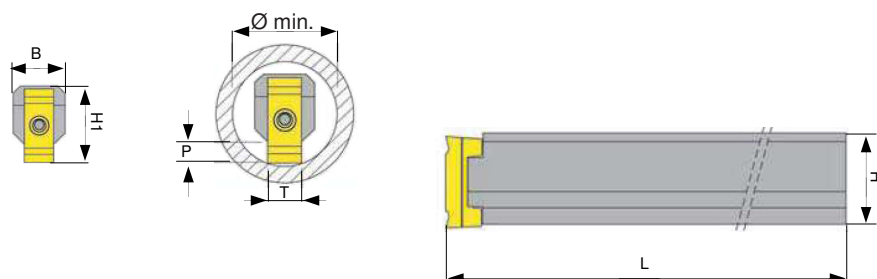
Herramienta diseñada para trabajar el ranurado.



Referencia	H	H1	B	L	T	Ø min.	P máx.	Cód. Hta		
PHZ/2 3625-14	36	37.5	25	300	14 16	44	8 9	19147PHZ2362514	19147551302014	19147TX225PLUS
PHZ/2 4838-18	48	50.0	32	400	18 20	58	12 13	19147PHZ2438318	19147551302103	19147DMN3124

CUCHILLAS MORTAJADORAS HZ/2

Características

Cuchilla Dos Filos 333TN: esta echa de HSS + PVD

Aplicación

En el mortajado vertical que es en general de 90° a causa de los movimientos de la mesa paralelos o Perpendiculares al filo de la herramienta.

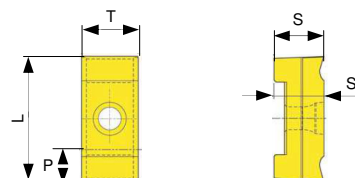

Referencia de la cuchilla	S	S1	L	P	T	Tolerancias en T	Calidad	Cód. Hta
HZ/2 14-14 C11	13.9	14	36	8	14	+0.205 +0.095	333TN	19147HZ21414C11
HZ/2 16-16 C11	13.9	14	36	9	16	+0.205 +0.095	333TN	19147HZ21616C11
HZ/2 18-18 C11	15.9	16	45	12	18	+0.205 +0.095	333TN	19147HZ21818C11
HZ/2 20-20 C11	15.9	16	45	13	20	+0.240 +0.110	333TN	19147HZ22020C11
HZ/2 14-14 H7	13.9	14	36	8	14	+0.018 -0	333TN	19147HZ21414H7
HZ/2 16-16 H7	13.9	14	36	9	16	+0.018 -0	333TN	19147HZ21616H7
HZ/2 18-18 H7	15.9	16	45	12	18	+0.018 -0	333TN	19147HZ21818H7
HZ/2 20-20 H7	15.9	16	45	13	20	+0.021 -0	333TN	19147HZ22020H7